



NKZ 3-phase
50Hz

Pump with agitator
- for professional use

All pumps in this series provide very smooth passage of sandy earth and slime. A forcibly cooled motor ensures long and continuous pump operations exposed to air.



Forced agitation

The agitator installed on the motor shaft extension forcibly agitates the fluid for easy and efficient transmission of sludge and slurry.

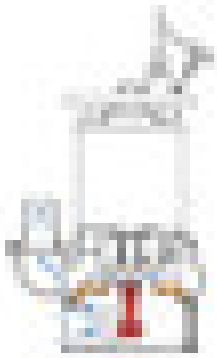

All pumps in this series provide very smooth passage of sandy earth and slime. A forcibly cooled motor ensures long and continuous pump operations exposed to the air. 4-pole motor used to achieve excellent durability and versatility. By offering a cast iron pump body durability is increased over standard aluminium body pumps. Spiral structure, marvelously facilitates the passage of sand, soil, sludge, or slime, without clogging.



Water jacket

Inner and outer motor casing - flow-through-design - perfect cooling under dry-run-conditions

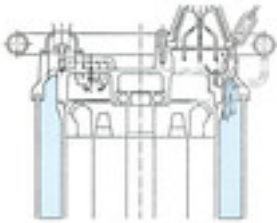

Components:

001 Cable	036 Lubricant
006 Cable entrance	050 Motor cover
020 Pump casing	052A Upper bearing
021 Impeller	052B Lower bearing
022 Suction plate	053 Motor protector
023 Strainer	054 Shaft
024 Agitator	055 Rotor
025 Mechanical seal	056 Stator
026A Oil sealing	060 Bearing housing
026B Oil sealing	064 Motor casing
029 Oil casing	065 Jacket
032. Outlet	068 Handle
035 Oil plug	

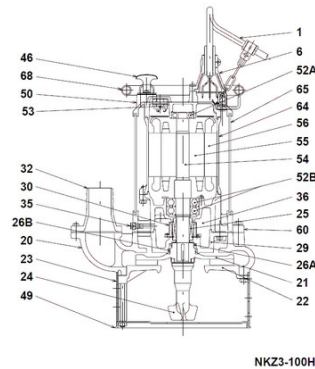

NKZ3-100H

